

# AS COMPETITION PAPER 2009

<b>Name</b>	
<b>School</b>	
<b>Town &amp; County</b>	

<b>Total Mark/50</b>

*Time Allowed: One hour*

*Attempt as many questions as you can.*

*Write your answers on this question paper.*

*Marks allocated for each question are shown in brackets on the right.*

*You may use any calculator.*

*You may use any public examination formula booklet.*

*Allow no more than **15 minutes** for **section A**.*

**The gravitational field strength on the earth is  $9.8 \text{ Nkg}^{-1}$**

## Section A: Multiple Choice

Circle the correct answer to each question. There is only one correct answer.

Each question is worth 1½ marks.

1. A child is standing on a set of bathroom scales in a lift (an elevator) measuring his mass. The mass which he reads on the scales is  $M$  whilst the lift is stationary. When the lift descends at a constant speed, which of the following statement is not correct?

- |                              |                                |   |   |
|------------------------------|--------------------------------|---|---|
| A. His mass remains the same | B. His weight remains the same | C. The reading on the scales depends on the speed of the lift | D. The reading on the scales remains the same |
|------------------------------|--------------------------------|---|---|

2. An ungraduated mercury thermometer is stuck to a 30 centimetre ruler, alongside the scale. The readings on the scale when the thermometer is at  $0.0\text{ }^{\circ}\text{C}$  and  $100.0\text{ }^{\circ}\text{C}$  are 36 mm and 61 mm respectively. The length of the mercury column varies linearly with temperature.

What is the temperature when the mercury is at the 43 mm mark?

- |                                |                                 |                                 |                                 |
|--------------------------------|---------------------------------|---------------------------------|---------------------------------|
| A. $4\text{ }^{\circ}\text{C}$ | B. $72\text{ }^{\circ}\text{C}$ | C. $58\text{ }^{\circ}\text{C}$ | D. $28\text{ }^{\circ}\text{C}$ |
|--------------------------------|---------------------------------|---------------------------------|---------------------------------|

3. A 750 kg car is moving at a speed of  $20.0\text{ ms}^{-1}$  when at a height of 5.0 m above the bottom of a hill when it runs out of fuel. The car coasts down the hill and then continues up the other side until it comes to rest. Ignoring frictional forces and air resistance, what is the value of  $h$ , the highest position the car reaches above the bottom of the hill?

- |        |         |         |         |
|--------|---------|---------|---------|
| A. 6 m | B. 15 m | C. 25 m | D. 45 m |
|--------|---------|---------|---------|

4. Light is an electromagnetic wave and can travel through a vacuum. There is a constant that appears in formulae which involve magnetism and is denoted by the letter  $\mu_0$  “mu zero”, whilst in electrostatic formulae another constant  $\epsilon_0$  “epsilon zero” will appear.

The speed of light in a vacuum is given by  $c = \frac{1}{\sqrt{\epsilon_0 \mu_0}}$ .

The units of  $\epsilon_0$  are  $\text{N}^{-1} \text{C}^2 \text{m}^{-2}$

The units of  $\mu_0$  are:

- A.  $\text{kg}^{-1} \text{m}^{-1} \text{C}^2$       B.  $\text{kg m C}^{-2}$       C.  $\text{kg m s}^{-4} \text{C}^{-2}$       D.  $\text{kg}^{-1} \text{s}^{-3} \text{C}^{-2}$

5. In the circuit, the resistors have identical resistances. If the power converted in  $R_1$  is  $P$ , what is the power converted in  $R_2$ ?

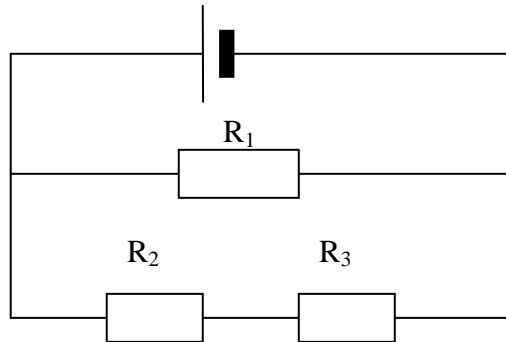

- A.  $P/4$       B.  $P/2$       C.  $P$       D.  $2P$

6. Three identical voltmeters each have a fixed resistance  $R$  which allows a small current to flow through them when they measure a potential difference in a circuit. The voltmeters,  $V_1$ ,  $V_2$ ,  $V_3$  are connected in the circuit shown below. The voltage-current characteristics of the device  $D$  are unknown. If  $V_2$  reads 2V and  $V_3$  reads 3V, what is the reading on  $V_1$ ?

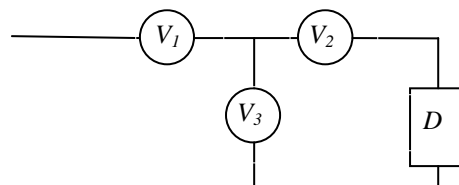

- A. 1V      B. 2.5V      C. 3V      D. 5V

7. A dipole bar magnet is shown in the diagram below, along with the pattern of field lines around it. A small steel ball bearing is placed at point O shown. What force would act upon the ball bearing?

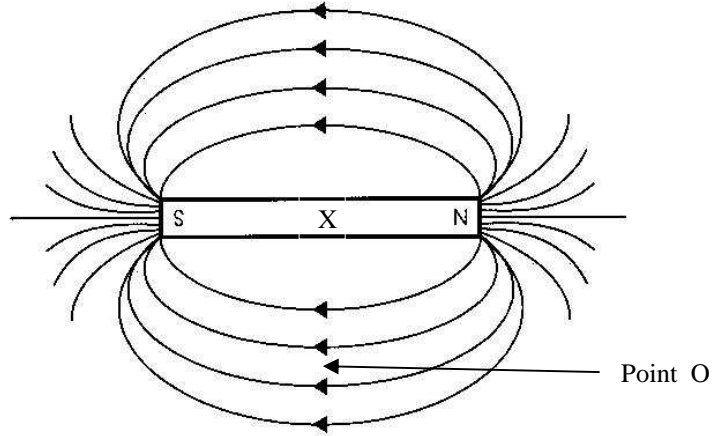

- A The ball bearing is in equilibrium and has no resultant force
- B The resultant force is along the field line, from north to south
- C The resultant force acts towards the centre point X of the bar magnet
- D The resultant force acts away from the centre point X of the magnet

8. An electric current flowing through a wire produces a magnetic field around the wire. Four wires carrying identical currents are shown placed at the corners of a square. The symbol  $\oplus$  indicates a current flowing along the wire into the page, and the symbol  $\odot$  indicates a current flowing along the wire pointing out of the page. In which of the diagrams is the magnetic field at the centre of the square greatest?

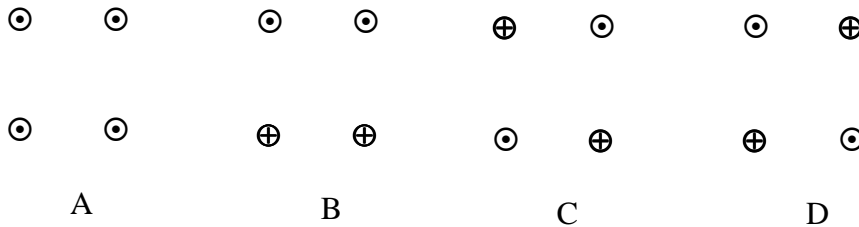

9. A wave on the surface of a liquid has amplitude  $A$  when it is emitted from the source of the wave, which is a dipper moving up and down in the liquid. The wave spreads out over the plane surface of the liquid, forming a circle of radius  $r$  which increases at the speed of the wave.

The energy of the wave is spread out over the circumference of the circle, so that as the circumference increases, the energy in a unit length of the circumference decreases as  $1/r$ . If the energy of the wave is proportional to the square of its amplitude  $A$ , then what is the new amplitude of the wave when  $r$  increases by four times from its previous value?

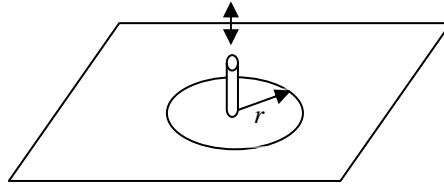

- A.  $A/2$                       B.  $A/4$                       C.  $A/8$                       D.  $A/16$

10. The graph above plots the measurements of the radioactive decay of an element, along with a line of best fit. Why do some of the data points not lie on the line of best fit, but appear above and below it?

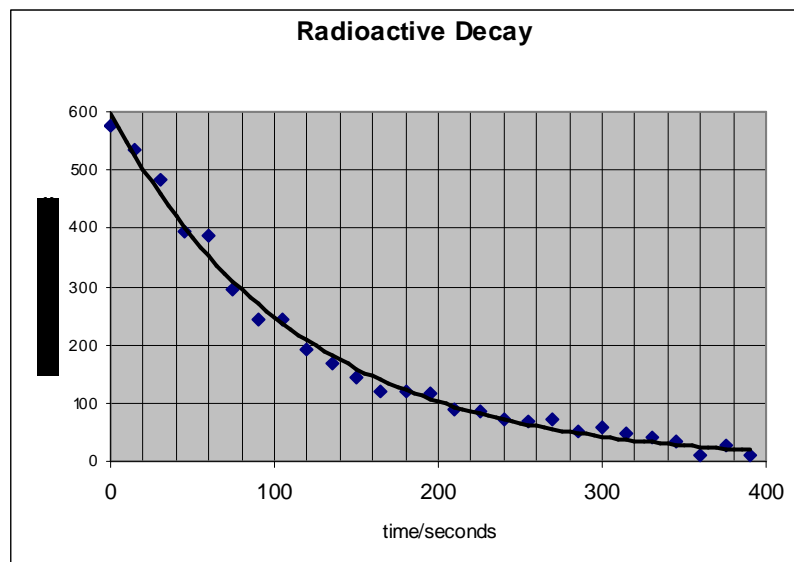

- A Not all of the  $\alpha$  or  $\beta$  or  $\gamma$  radiations are measured      B The source decays in a random manner      C The background count is not zero      D Inaccurate measurements by the experimenter

## Section B: Written Answers

### Question 11.

A plane accelerates from rest to take off from a runway. There is a point of no return where the pilot will not be able to stop the plane before the end of the runway if he fails to take off. The runway is 2 km long and the plane can accelerate at  $3 \text{ ms}^{-2}$  and can decelerate at  $2 \text{ ms}^{-2}$ . We can calculate the length of time available from the start of the take off to the point of no return.

- a) Sketch a graph of the speed of the plane against time for the situation where the plane fails to take off but the whole length of the runway is used. (no values are required)

[2]

- b) If  $t_1$  is the time taken for the plane to reach its maximum speed  $v$ , and  $t_2$  is the time taken for it to decelerate before it goes beyond the end of the runway, express  $v$  in terms of  $t_1$  and  $t_2$ , and the respective accelerations.

---

---

---

[2]

- c) Calculate the distance  $s_1$  travelled by the plane whilst accelerating, in terms of  $t_1$ , and the distance  $s_2$  travelled by the plane whilst decelerating, in terms of  $t_2$ .

---

---

---

[2]

- d) From your answers to (b) and (c), calculate the value of  $t_I$ , the time taken to reach the point of no return, given that the runaway is 2 km long.

---

---

---

---

[2]

/8

### Question 12.

A stream of water flows vertically downwards from a running tap, as shown below. Some way down the flow, there is a 3 cm long segment of flowing water where the diameter of the circular stream reduces from  $d_1 = 5$  mm to a diameter  $d_2 = 4$  mm. From this we can determine the flow rate and how long it will take to fill a beaker of volume  $200 \text{ cm}^3$ . We shall assume that water is incompressible.

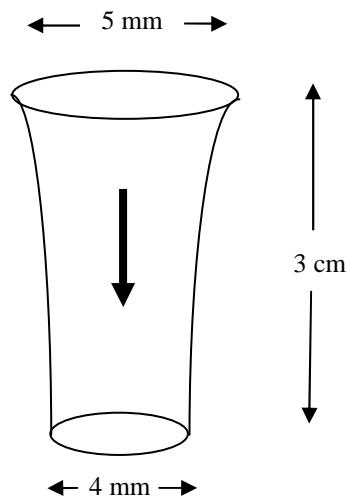

- a) Explain why the segment of water becomes narrower.

---

---

---

[2]

b) If the speed of the water at the top of the segment is  $v_1$  then what is the speed  $v_2$  of the water at the bottom of the segment expressed in terms of  $v_1$ ,  $d_1$  and  $d_2$  ?

---

---

---

[1]

c) Calculate the speed of the water flow at the top of the segment.  
You may want to use the equation of motion  $v^2 - u^2 = 2as$

---

---

---

[3]

d) From your answer to part (b), calculate the volume flow of water per second.

---

---

---

[1]

e) Calculate the time taken to fill a  $200 \text{ cm}^3$  beaker.

---

---

---

[1]

/8



### Question 13.

This question requires you to consider the units of each quantity in order to follow the calculation.

In order to reduce its diameter, a wire is pulled through a small hole in a metal plate. The wire is made of metal whose specific heat capacity is  $400 \text{ J kg}^{-1} \text{ }^\circ\text{C}^{-1}$  and, on emerging from the hole, has a mass per unit length of 5 g per m. A steady force of 600 N is required. If all the heat generated is retained in the wire, we can calculate the rise in temperature of the wire.

Calculate all quantities using SI units (metre, kilogram, second).

- a) Draw a simple sketch of the situation and mark on it the force applied to the thin wire.

[1]

- b) What is the value of the work done on one metre length of the wire?

---

---

[1]

- c) How much work is done on one kilogram of wire?

---

---

[1]

- d) Assuming all of the work done is converted into heat calculate the temperature rise of the wire.

---

---

---

---

[2]

If, however, the temperature of the wire were kept constant by spraying it with cold water, then we can calculate what mass of water would be needed.

Specific heat capacity of water is  $4,200 \text{ J kg}^{-1} \text{ }^\circ\text{C}^{-1}$

- e) Calculate the mass of wire, in kilograms, that is produced each second if it emerges from the hole at a speed of  $8.4 \text{ ms}^{-1}$ .

---

---

---

[2]

- f) Using your answer from part (c), calculate the work done on the wire each second.

---

---

---

[1]

- g) If the temperature rise of the water were to be  $12 \text{ }^\circ\text{C}$ , calculate the mass of water used each second to keep the temperature constant.

---

---

---

[2]

/10

### Question 14.

- a) A laser produces light pulses of energy 5 J and duration  $2 \times 10^{-9}$  s. If the beam is circular in cross section and of diameter 2 mm, calculate the intensity (the power per unit area) of a laser pulse.

---

---

---

[1]

- b) State one significant difference in the nature of the light emitted by a laser from that emitted by an ordinary light bulb.

---

---

[1]

- c) The wavelength of the laser is 400 nm. Light can be seen either as a wave or a particle (a photon). The energy  $E$  of a photon of light is given by  $E = hf$ , where  $f$  is the frequency of the light and  $h$  is Planck's constant. Calculate the number of photons in a single pulse from the laser.

$$\text{Planck's constant } h = 6.6 \times 10^{-34} \text{ Js}$$
$$\text{speed of light } c = 3.0 \times 10^8 \text{ ms}^{-1}$$

---

---

---

[2]

- d) Calculate the volume of a single pulse of light from the laser, and hence the density of photons in the laser pulse.

---

---

---

[3]

- e) If the photons in the pulse were equally spaced, rather like ball bearings packed uniformly in a box, what would be the volume occupied by a single photon?

---

---

[1]

- f) If the volume occupied by a photon was a cube, what would be the length of a side of the cube?

---

---

[1]

/9